

**ELEVATION OF ALSW -18 AND ALSW - 15**  
2 TRACK ALUMINIUM WINDOW  
SCALE - 1:25

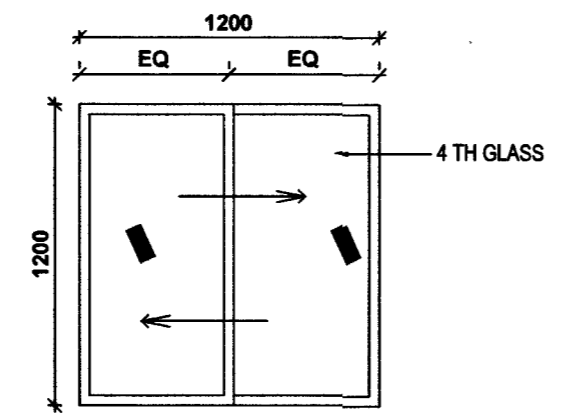

**ELEVATION OF ALSW-12**  
2 TRACK ALUMINIUM WINDOW  
SCALE - 1:25

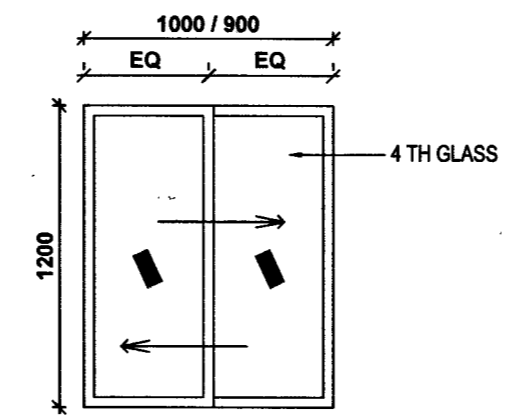

**ELEVATION OF ALSW-10 AND ALSW-9**  
2 TRACK ALUMINIUM WINDOW  
SCALE - 1:25

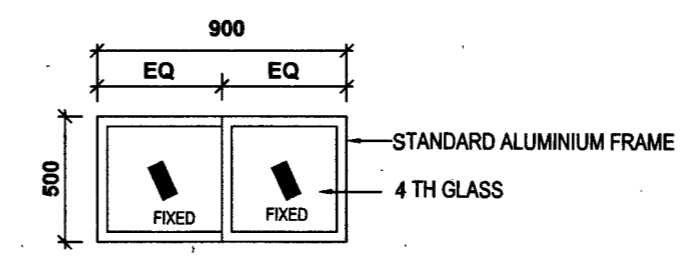

**ELEVATION OF ALV - 9**  
SCALE - 1:25

**DETAILS OF ALUMINIUM SLIDING WINDOWS AND VENTILATORS WITHOUT MOSQUITO PROOFING**

- NOTES :-**
- CONTRACTOR TO CHECK & VERIFY ALL DIMENSIONS BEFORE EXECUTION OF THE WORK.
  - FIGURED DIMENSIONS SHALL BE FOLLOWED.
  - ALL DIMENSIONS ARE GIVEN IN MM UNLESS OTHERWISE MENTIONED.
  - EXECUTIVE AUTH SHALL CHECK ALL THE DRGS, ANY DISCREPANCY SHALL BE BROUGHT TO THE NOTICE OF THIS HQ.
  - FOR ALL OTHER DETAILS OF SLIDING ALUMINIUM WINDOWS REF DRG NO:- CEPZ / 2013 / TD / 01 SHEET NO - 1/2 TO 2/2.
  - STANDARD ALUMINIUM GRILLS SHALL BE PROVIDED TO ALL ALUMINIUM WINDOWS AND VENTILATORS
  - GASKETS:-**
    - GASKET MADE OF ETHYL PROPYLENE DIAMINE MONOMER (EPDM) SHALL BE OF OSAKA, MAHARASHTRA RUBBER, AVIGIRI, MANGLAM INDUSTRIES, ALBOSS MAKE.
    - CORNER BRACKETS AND MULLION CAPS MADE OF NYLON/POLYPROPYLENE.
  - GLASS:-** GLAZED SHUTTER AND FIXED PORTIONS SHOULD BE OF MINIMUM 4 MM THK TOUGHENED (OR NEAREST HIGHER SIZE) THICKNESS & SHALL BE OF SAINT GOBAIN, MIDIGUARD OR ASAHI MAKE (PLAIN SHEET GLASS PANES SHALL BE PROVIDED TO ALL WINDOWS UNLESS OTHERWISE MENTIONED AND IN TOILET, WC, BATH FROSTED GLASS SHALL BE PROVIDED.)
  - GRILL:-** WINDOWS AND VENTILATORS SHALL BE PROVIDED WITH STANDARD ALUMINIUM GRILL. TOTAL GRILL UNIT SHOULD BE POWDER COATED WITH MATCHING COLOUR OF WINDOW AND FIXED TO WINDOW FRAME WITH POP RIVETS/ANCHOR FASTENER.

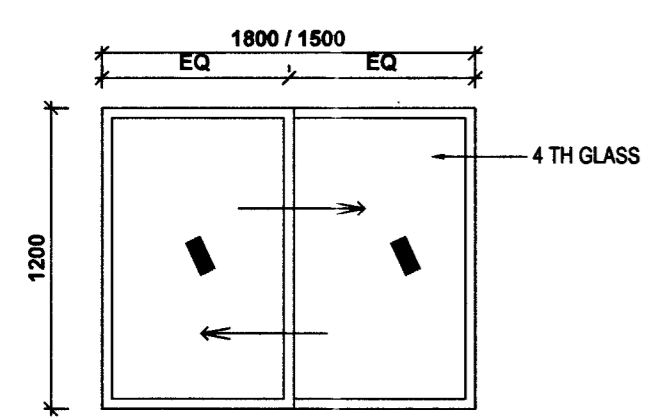

**ELEVATION OF ALSW -18M AND ALSW - 15M**  
3 TRACK ALUMINIUM WINDOW WITH MOSQUITO PROOFING  
SCALE - 1:25

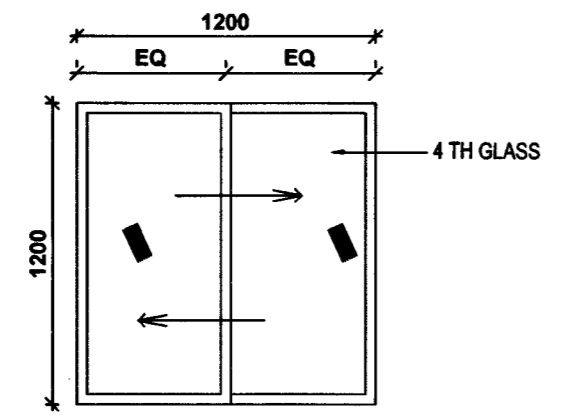

**ELEVATION OF ALSW-12M**  
3 TRACK ALUMINIUM WINDOW WITH MOSQUITO PROOFING  
SCALE - 1:25

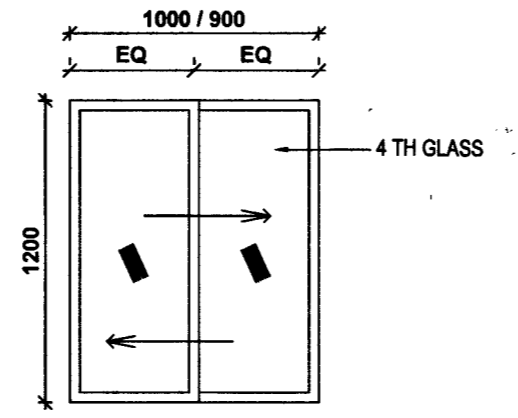

**ELEVATION OF ALSW-10M AND ALSW-9M**  
3 TRACK ALUMINIUM WINDOW WITH MOSQUITO PROOFING  
SCALE - 1:25

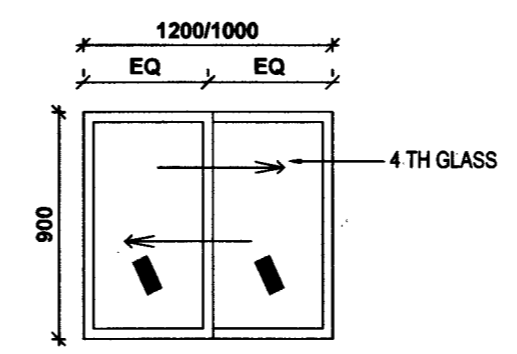

**ELEVATION OF ALSW-12M @ AND ALSW-10M @**  
3 TRACK ALUMINIUM WINDOW WITH MOSQUITO PROOFING  
SCALE - 1:25

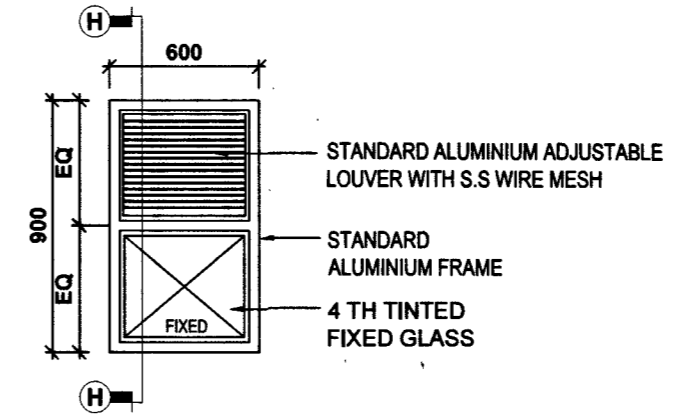

**ELEVATION OF ALV -6M WITH MOSQUITO PROOFING**  
SCALE - 1:25

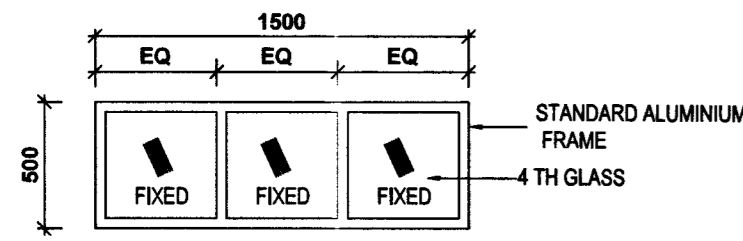

**ELEVATION OF ALV - 15**  
SCALE - 1:25

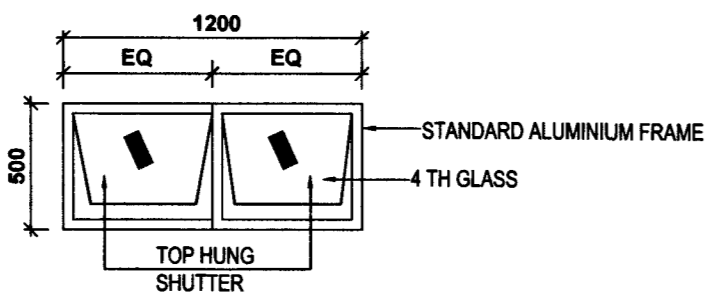

**ELEVATION OF ALV - 12M WITH MOSQUITO PROOFING**  
SCALE - 1:25

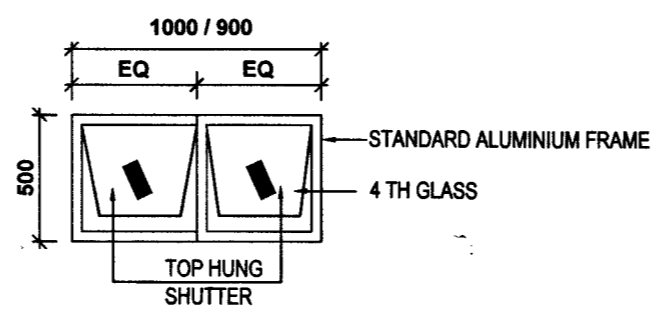

**ELEVATION OF ALV - 10M AND ALV -9 M WITH MOSQUITO PROOFING**  
SCALE - 1:25

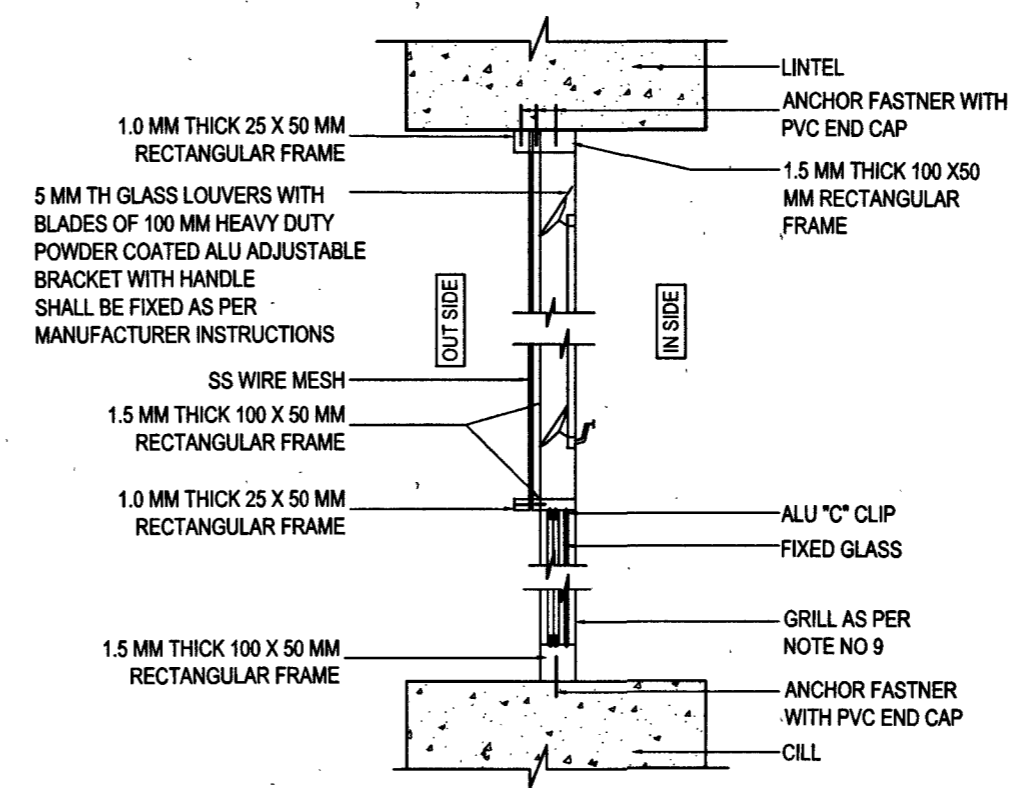

**SECTION AT "H-H"**

**DETAILS OF ALUMINIUM SLIDING WINDOWS AND VENTILATORS WITH MOSQUITO PROOFING**

SN	DATE	DESCRIPTION	INITIAL
<b>REVISION</b>			
<b>ELEVATIONS OF ALUMINIUM WINDOWS &amp; SECTION "H-H"</b>			
DRN	NB SUB VAJIR	<b>CHIEF ENGINEER PUNE ZONE</b>	SHT. No.
DATE	10 MAR 2023		1/1
TCD			
CKD			
SCALE	AS SHOWN	DRG NO. :- CEPZ / 2023 / TD / 02	
<i>[Signature]</i> AAD (ARCH)		<i>[Signature]</i> DY DIR (ARCH)	
		<i>[Signature]</i> DIR (ARCH) FOR CHIEF ENGINEER PUNE ZONE	